

---

# An *ex vivo* evaluation of a new root canal irrigation technique with intracanal aspiration

Y. Fukumoto, I. Kikuchi, T. Yoshioka, C. Kobayashi & H. Suda

Pulp Biology and Endodontics, Graduate School, Tokyo Medical and Dental University, Tokyo, Japan

---

## Abstract

**Fukumoto Y, Kikuchi I, Yoshioka T, Kobayashi C, Suda H.**

An *ex vivo* evaluation of a new root canal irrigation technique with intracanal aspiration. *International Endodontic Journal*, **39**, 93–99, 2006.

**Aim** To evaluate the effectiveness of a new root canal irrigation technique with intracanal aspiration in removing the smear layer and to assess irrigant extrusion *ex vivo*.

**Methodology** Thirty-five instrumented canals of extracted human canine teeth that had been resected apically by removing 3 mm of the root tip were divided into one control and four experimental groups of seven teeth each. The roots were fixed in a plastic case and surrounded with normal saline agar coloured with 1% acid red. No irrigation was performed in the control teeth. Each root canal in the experimental groups was irrigated with 9 mL of 14% ethylenediaminetetraacetic acid for 3 min, and then with 6 mL of 6% sodium hypochlorite (NaOCl) for 2 min. In the intracanal aspiration technique, the irrigant was delivered from the tip of an injection needle placed 12 mm from the apical root-end and an aspiration needle that was connected to a Root ZX<sup>TM</sup> apex locator placed 2 and 3 mm short of the apical root-end in groups 1 and 2, respectively. In the conventional method, the tip of an injection needle used for delivery of the irrigant and as an active electrode was placed 2 and 3 mm short of the

apical root-end in groups 3 and 4, respectively, the tip of the aspiration needle was placed 12 mm from the apical root-end in these groups. The readings of the Root ZX<sup>TM</sup> during irrigation were recorded. The cleanliness of the canal was evaluated by scoring smear layer from scanning electron microscopy (SEM) images of the canal. Extrusion of NaOCl was detected by measuring the discoloured area of the agar around the apical root-end. The data obtained were statistically analysed by one-way ANOVA, the Kruskal–Wallis test and Friedman's test.

**Results** In the SEM study, the canals in groups 1–3 were significantly cleaner than those in the control and group 4 ( $P < 0.05$ ). The mean Root ZX<sup>TM</sup> readings in groups 1–3 were approximately '0.5'. The discoloured area in group 3 was significantly larger than the other groups ( $P < 0.05$ ).

**Conclusions** Irrigation using the intracanal aspiration technique allowed more effective removal of the smear layer than that performed by the conventional method in an apically resected canine tooth. The intracanal aspiration technique produced limited extrusion of the irrigant beyond the apical foramen.

**Keywords:** intracanal aspiration technique, root canal irrigation, Root ZX, smear layer.

Received 4 August 2004; accepted 15 August 2005

---

## Introduction

It is often difficult to clean the apical portion of the root canal with conventional irrigation methods, because of

its complicated anatomy (Garberoglio & Becce 1994). Although the combined use of ethylenediaminetetraacetic acid (EDTA) and sodium hypochlorite (NaOCl) solutions has been recommended for the removal of smear layer from the surface of the root canal wall (Yamada *et al.* 1983, Cengiz *et al.* 1990, Garberoglio & Becce 1994), it has not been confirmed whether the irrigants affect the apical one-third of the canal. A study evaluating the efficacy of three kinds of salts of

---

Correspondence: Yasue Fukumoto, Pulp Biology and Endodontics, Graduate School, Tokyo Medical and Dental University, 5-45 Yushima 1-chome, Bunkyo-Ku, Tokyo 113-8549, Japan (e-mail: y.fukumoto.endo@tmd.ac.jp).

EDTA and NaOCl delivered alternately using a Monoject syringe with a 27-gauge needle reported that the demineralization properties of the solutions were adequate in the coronal two-thirds of the canals, but were less effective in the apical third (O'Connell *et al.* 2000). Even after EDTA and NaOCl irrigation with a specially developed needle, which was perforated on its side and closed at the end, placed within 1 mm of the working length, it was noted that a large amount of smear layer remained in the apical region of root canals (Goldman *et al.* 1976, Yamada *et al.* 1983).

Ultrasonics were introduced into root canal treatment by Richman (1957), and ultrasonic devices have been developed for root canal irrigation. Even with ultrasonic irrigation using NaOCl and EDTA, smear layer remained in the apical region of canals (Ciucchi *et al.* 1989, Cameron 1995). Guerisoli *et al.* (2002) reported that smear layer was removed from the apical third of the canals as well as from the cervical and middle thirds of the canals by EDTAC and NaOCl with a size 15 file energized by ultrasonic agitation and introduced 1 mm from the anatomical apex. However, excess cutting of canal dentine and extrusion of the irrigant beyond the apex are matters of concern (Kobayashi *et al.* 2003).

The mechanical and chemical effectiveness of an irrigation regimen depends on its ability to contact the entire canal system (Ciucchi *et al.* 1989). Although the irrigant must be in direct contact with the internal canal surfaces for effective action, it is often difficult for the irrigant to approach the apical portion of the canal because of its small diameter (Guerisoli *et al.* 2002). Some studies suggested that the tip of an injection needle should be placed as close as possible to the apical end of the canal for effective cleaning of the entire length of the root canal (Goldman *et al.* 1976, Abou-Rass & Piccinino 1982, Sedgley *et al.* 2005). However, if the tip of the needle is placed too close to the apical foramen, the chances of extrusion of the solution increases (Druttman & Stock 1989). Extrusion of an irrigant, such as NaOCl, often results in severe periapical tissue damage (Hülsmann & Hahn 2000, Gernhardt *et al.* 2004).

As an effective and safe irrigation technique for the removal of smear layer from the apical portion has not yet been established, a new irrigation technique was designed with intracanal aspiration using both an aspiration needle and an injection needle in an attempt to minimize extrusion of the irrigant through the apical foramen (Fukumoto *et al.* 2004, Fukumoto 2005). The aim of this study was to evaluate the effectiveness of the

intracanal aspiration technique in removing smear layer and minimizing irrigant extrusion beyond the apical foramen *ex vivo*.

## Materials and methods

The roots of 35 extracted human maxillary canine teeth preserved in 0.01% thymol solution were used; the root lengths were adjusted to 18 mm. The coronal portion of the canal was flared using Gates Glidden drills sizes 1–4 (Mani Inc., Tochigi, Japan), and canal patency confirmed using a size 10 K-file (Zipperer, Munich, Germany). The root canals were instrumented in a crown down sequence with size 20 GT<sup>TM</sup> rotary instruments in tapers increasing from 0.06 to 0.10 (Dentsply Maillefer, Ballaigues, Switzerland) driven by the Tri Auto ZX<sup>TM</sup> (Morita Co., Tokyo, Japan), and washed with 6% NaOCl solution between each instrument change. Root canal preparation was completed when the tip of the size 20, 0.10 taper GT<sup>TM</sup> rotary instrument reached the apical foramen. Then, 3 mm of the apical root was removed, so that each root was 15 mm in length and 0.5 mm in diameter at the apical foramen. After washing with 10 mL of distilled water, the root canal was filled with silicone (Examixfine<sup>®</sup> Regularhard, GC Co., Tokyo, Japan) to avoid invasion of normal saline agar (Bacto<sup>TM</sup> Agar, Difco, Detroit, MI, USA) into the canal. The root was then secured in a plastic case (22 × 32 × 4 mm<sup>3</sup>) using self-curing resin (Unifast II, GC Co.) (Fig. 1). Normal saline agar coloured with 1% acid red (Caries Detector, Kuraray Co., Ltd., Osaka, Japan), used to evaluate the extrusion of the NaOCl solution, was poured into the plastic case. After the agar had set, the silicone material in the canal was removed with an explorer.

The specimens were randomly divided into one control and four experimental groups of seven teeth each. In the control group, no further irrigation of the root canal was performed. In groups 1 and 2, the root canal was irrigated using the intracanal aspiration technique (Fig. 1). The irrigant was delivered using a tubing pump (Masterflex<sup>®</sup> 7524-40, Cole-Parmer Instrument Co., Vernon Hills, IL, USA) at a flow rate of 3.0 mL min<sup>-1</sup>. The tip of an injection needle (external diameter: 0.41 mm, internal diameter: 0.19 mm; Blunt<sup>®</sup>, Nipro Co., Osaka, Japan) was placed in the canal 12 mm from the apical root-end. Another needle (external diameter: 0.55 mm, internal diameter: 0.30 mm; Terumo Co., Tokyo, Japan) was used for aspiration and connected to the Root ZX<sup>TM</sup> (Morita Co.). The Root ZX<sup>TM</sup>, an electronic apex locator, uses

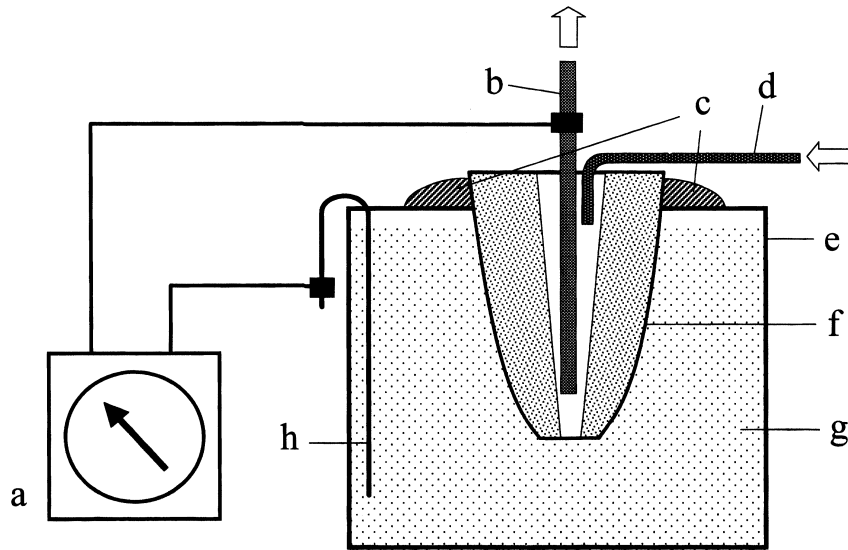

**Figure 1** Experimental setup of intracanal aspiration technique (IAT). (a) Root ZX. (b) Aspiration needle. (c) Self-curing resin. (d) Washing needle. (e) Plastic case. (f) Tooth. (g) Coloured agar. (h) Neutral electrode. The irrigant injected from the tip of the washing needle (d) was ejected by the tip of the aspiration needle (b).

the ratio method that simultaneously measures the impedance of two different frequencies, calculates the quotient of the impedances, and expresses this quotient in terms of metre value, which is directly related to the position of the tip of an active electrode (Kobayashi & Suda 1994, Kobayashi 1995). The pointed edge of the aspiration needle was ground flat, and the tip of the needle was placed 2 and 3 mm short of the apical root-end (Fukumoto *et al.* 2004) in groups 1 and 2, respectively. The aspiration pressure of the suction unit (Minic-W, Shin-ei Industries, Saitama, Japan) was maintained at  $-20$  kPa.

In groups 3 and 4, the root canal was irrigated using a conventional irrigation method by placing the injection needle deep in the canal, which is the technique generally used. An injection needle, connected to the Root ZX<sup>TM</sup>, was placed 2 and 3 mm short of the apical root-end in groups 3 and 4, respectively. The tip of the aspiration needle was placed 12 mm from the apical root-end.

Each root canal was irrigated with 9 mL of 14% EDTA for 3 min and then with 6 mL of 6% NaOCl for 2 min. The readings of the Root ZX<sup>TM</sup> were recorded when they became stable. The readings recorded were analysed statistically by one-way analysis of variance (ANOVA), with the significance level set at 5%.

After irrigation, the colour change within the agar was recorded by an image scanner (GT9600, Seiko

Epson Co., Tokyo, Japan). The magnitude of the discoloured area was calculated using Photoshop<sup>®</sup> software (version 7.0, Adobe, San Jose, CA, USA) in a  $100\text{ mm}^2$  area ( $316 \times 316$  pixels), the centre of which was located at the apex. The ratios of the discoloured area to the total area evaluated were analysed statistically by one-way ANOVA, with the significance level set at 5%.

Finally, the roots were removed from the case and the root canals were washed with 10 mL of distilled water. The apical 5 mm of each root was sectioned and then split longitudinally into two halves in its buccolingual aspect, in preparation for SEM observation. The specimens were dehydrated in graded series of ethanol solutions, coated with platinum and then observed under SEM (S-4500, Hitachi High-Technologies Co., Tokyo, Japan) at 15 kV. Areas at 0, 1, 2 and 3 mm from the apex were photographed at  $500\times$  magnification.

The openings of the dentinal tubule and the structure of the intertubular dentine in each image were assessed in accordance with the criteria proposed by Torabinejad *et al.* (2003) as follows; 0: most/all tubule openings obscured and no dissolution of the intertubular dentine; 1: most tubules open, but no dissolution of the intertubular dentine; 2: all tubules open, but no dissolution of the intertubular dentine; 3: all tubules open and partial dissolution of the intertubular dentine;

and 4: all tubules open and considerable dissolution of the intertubular dentine. The scoring was conducted by three evaluators who were blinded to the classification of the experimental groups. In the event of discrepant scores, a consensus was reached by discussion among the three evaluators. Statistical analysis was performed by the Kruskal–Wallis test and Friedman’s test, with the level of significance set at 5%.

## Results

Figure 2 shows representative SEM images with scores of 2, 3 and 4. Figure 3 shows the results of the SEM observations. In the control group, the smear layer covered the surfaces of the dentinal wall, and the tubule openings could scarcely be observed in the examined area. Group 1 had the best results, and scores in this group were significantly different from those in the other groups ( $P < 0.05$ ). In each group, the score was significantly more favourable at a point 3 mm from the apex than the other areas evaluated ( $P < 0.05$ ).

Figure 4 shows the mean metre reading of Root ZX™ in each experimental group during root canal irrigation using NaOCl and EDTA. Group 4 had a significantly higher mean reading of 2.7 than the other experimental groups ( $P < 0.05$ ).

Figure 5 shows representative images of the colour change caused by irrigant extrusion and Fig. 6 shows the ratio of the discoloured area to the unit area evaluated after irrigation. Group 3 had a significantly higher value than the other experimental groups ( $P < 0.05$ ).

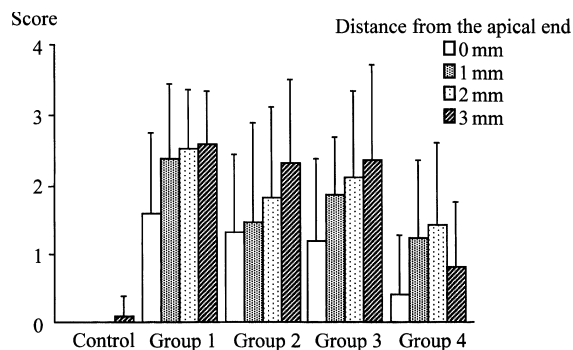

**Figure 3** Mean smear layer removal scores of each group under scanning electron microscopy observation ( $n = 7$ ).

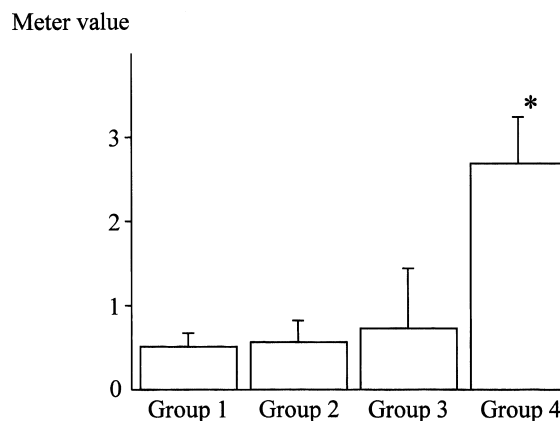

**Figure 4** Metre values of the Root ZX during irrigation. Metre value 0.5 indicates that the tip of the active electrode reached the apical constriction. \*Significant difference from other three groups:  $P < 0.05$  (Fisher’s Protected Least Significant Difference).

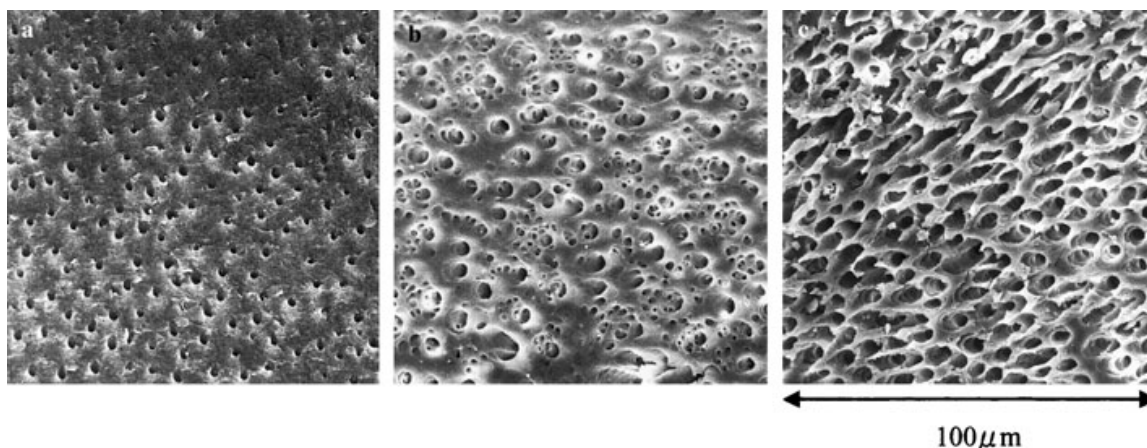

**Figure 2** Scanning electron microscopy images of dentin surfaces. (a) One millimetre from the apex in group 1, score = 2; (b) 1 mm from the apex in group 2, score = 3 and (c) 1 mm from the apex in group 1, score = 4.

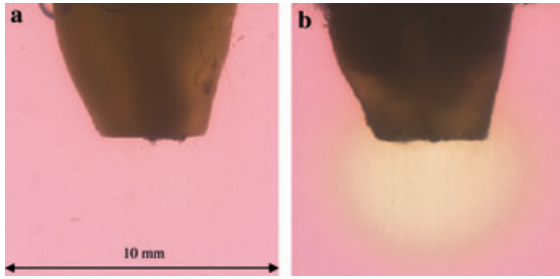

**Figure 5** Discoloration of agar after irrigation. (a) Group 1. No colour change. (b) Group 3. Discoloration of agar due to irrigant extrusion was obvious.

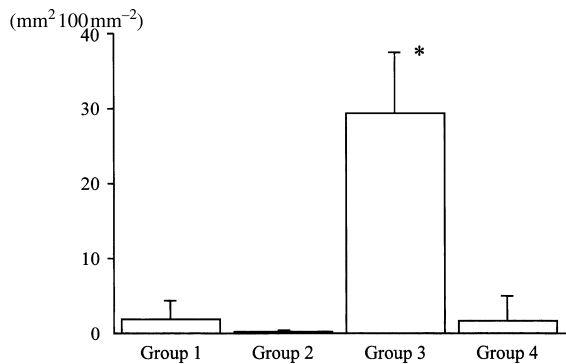

**Figure 6** Ratio of discoloured area to evaluated area. \*Significant difference from other three groups:  $P < 0.05$  (Fisher's PLSD).

## Discussion

In general, there are relatively fewer dentinal tubules per unit area in the apical portion of the root canal wall (Whittaker & Kneale 1979). These tubules are inherently smaller, and often sclerosed (Carrigan *et al.* 1984), which makes it difficult to evaluate the cleanliness of the apical canal compared to the middle or coronal region. Therefore, in this study, 3 mm from the apical part of the root was removed, and the effect of root canal irrigation on the apical portion was evaluated in areas at 0, 1, 2 and 3 mm from the modified root-end. The removal of the apical constriction of these teeth also facilitated easier placement of the aspiration needle. However, the cleaning effects without an apex might be different from that of a tooth with a normal apical constriction. Further study would be necessary to apply this technique to normal teeth.

The scoring system for smear layer removal used in this study was based on the criteria proposed by

Torabinejad *et al.* (2003). They evaluated the presence or absence of the smear layer by openings of the dentinal tubules and the occurrence of dentine erosion.

A score of 3 or 4 implied dentine erosion, with a rough appearance of the root canal wall and irregularly enlarged orifices of the dentinal tubules. This rough appearance of the dentine in the root canal wall and irregularly enlarged dentinal tubule orifices were considered morphological changes caused by decalcification of the inorganic component by EDTA and the dissolution of the organic matrix by NaOCl (Niu *et al.* 2002).

The results of the SEM observation (Fig. 2) suggested that root canal irrigation using the intracanal aspiration technique was as effective as the conventional irrigation method in removal of the smear layer when the tip of the injection needle was placed close to the end of the canal. This result of the conventional irrigation method supports previous reports (Goldman *et al.* 1976, Abou-Rass & Piccinino 1982). In the intracanal aspiration technique, the irrigant is introduced from the tip of the injection needle placed in the coronal part of the canal, and then aspirated via the tip of the aspiration needle placed close to the apex. Therefore, circumfluence of the irrigant was achieved, especially in the apical region, and the irrigation was effective for removal of smear layer. On the contrary, the irrigant could approach the root-end in group 3 because apical irrigant pressure developed by the injection needle of group 3 would be higher than that of group 4. Bradford *et al.* (2002) reported that greater apical pressure was developed when the tip of an injection needle was placed closer to the end of the canal.

The Root ZX<sup>TM</sup>, an electronic apex locator, was developed to determine accurate canal length (Kobayashi & Suda 1993, 1994, Kobayashi 1995), and the reading of '0.5' corresponds to an electrode reaching the apical constriction (Kobayashi & Suda 1993). The accuracy of the Root ZX<sup>TM</sup> in the detection of the apical constriction has been reported in many studies (Shabahang *et al.* 1996, Vajrabhaya & Tepmongkol 1997, Dunlap *et al.* 1998, Pagavino *et al.* 1998, Ounsi & Naaman 1999, Jenkins *et al.* 2001, Goldberg *et al.* 2002, Meares & Steiman 2002, Kielbassa *et al.* 2003). However, the role of the irrigant, not an injection needle, as an active electrode for a complete electrical circuit with the Root ZX<sup>TM</sup> during irrigation of a wide canal with a large foramen has not been reported previously.

In this study, the readings of the Root ZX™ were stable between 2.0 and 3.0 in all groups before delivery of the irrigant into the root canal. These readings indicated that the tip of the needle did not reach the root-end. However, during irrigation, the readings changed and became approximately '0.5' in groups 1–3. As results of the SEM study suggested that the irrigant reached the root-end in these groups, it is possible that the electrolytic irrigants, NaOCl and EDTA, may have replaced the air trap between the tip of the needle and the apex in the canal and the reading became 0.5. On the contrary, in group 4, the irrigant may not have reached the root-end because the smear layer was not removed in the apical area and the reading during irrigation remained high and did not become 0.5. Thus, it appears that the reading of the Root ZX™ during irrigation represented the deepest penetration length of the irrigants, NaOCl and EDTA.

In a preliminary study, the movement of irrigant was assessed in the apical area of a transparent root canal model on a magnified view with the CCD camera (VH-8000, Keyence Co., Osaka, Japan). This transparent model made of polypropylene with an apical diameter of 0.5 mm was fixed in a plastic case and surrounded with normal saline agar. The injection needle, which was placed 2 mm from the apex in the root canal, was attached to the file holder of the Root ZX™. The irrigant, NaOCl or EDTA, was delivered into the canal. When the irrigant reached the apex, the reading of the Root ZX™ moved to '0.5' from the original position that was around '3.0'. This preliminary study suggested that the irrigant could be regarded as an active electrode.

The colour of normal saline agar stained with 1% acid red changed because of the bleaching effect of NaOCl. Therefore, areas of discoloration indicated the presence of extruded NaOCl. The amount of extruded NaOCl in group 3 was significantly greater than that in groups 1, 2 and 4. This result suggests that extrusion of the irrigant is probably less likely when the intracanal aspiration technique is employed. The irrigant not only reached the root-end but also extruded through it in group 3. However, the irrigant extruded little when using the intracanal aspiration technique (groups 1 and 2) indicating that the irrigant could reach the root-end without extrusion in these groups. These results further support a previous report (Fukumoto *et al.* 2004).

It may be difficult for the conventional irrigation method to control the movement of irrigant in the apical region of the canal. Although group 3 showed

the reading of the Root ZX™ to be '1.0', which meant the active electrode was inside the canal, considerable extrusion of the irrigant was observed. Precise placement of the irrigant could not be monitored using the Root ZX™ in the conventional irrigation method.

The results of this study suggest that the Root ZX™ readings during the intracanal aspiration technique allowed monitoring of the apical position of the irrigant and those of groups 1 and 2 represented the most appropriate working length readings. Lussi *et al.* (1993) measured the electrical resistance of periapical solution in an *ex vivo* study of noninstrumentation technology to detect the completion of root canal preparation, but they did not make any attempt to apply this method clinically (Lussi *et al.* 1997). As this phenomenon was only observed when a strong electrolyte was used as an irrigant and the apical foramen was large, further research may be needed to apply this technique in clinical situations.

## Conclusions

Root canal irrigation using the intracanal aspiration technique was effective in removing the smear layer in the apical region of modified root canals, without extrusion of the irrigant. The reading of the Root ZX™ during irrigation made it possible to monitor whether or not the irrigant had reached the apical end of the root canal.

## References

- Abou-Rass M, Piccinino MV (1982) The effectiveness of four clinical irrigation methods on the removal of root canal debris. *Oral Surgery, Oral Medicine, and Oral Pathology* **54**, 323–8.
- Bradford CE, Eleazer PD, Downs KE, Scheetz JP (2002) Apical pressures developed by needles for canal irrigation. *Journal of Endodontics* **28**, 333–5.
- Cameron JA (1995) Factors affecting the clinical efficiency of ultrasonic endodontics: a scanning electron microscopy study. *International Endodontic Journal* **28**, 47–53.
- Carrigan PJ, Morse DR, Furst ML, Sinai IH (1984) A scanning electron microscopic evaluation of human dentinal tubules according to age and location. *Journal of Endodontics* **10**, 359–63.
- Cengiz T, Aktener BO, Piskin B (1990) The effect of dentinal tubule orientation on the removal of smear layer by root canal irrigants. A scanning electron microscopic study. *International Endodontic Journal* **23**, 163–71.
- Cucchi B, Khettabi M, Holz J (1989) The effectiveness of different endodontic irrigation procedures on the removal of

- the smear layer: a scanning electron microscopic study. *International Endodontic Journal* **22**, 21–8.
- Druttman ACS, Stock CJR (1989) An *in vitro* comparison of ultrasonic and conventional methods of irrigant replacement. *International Endodontic Journal* **22**, 174–8.
- Dunlap CA, Remeikis NA, BeGole EA, Rauschenberger CR (1998) An *in vivo* evaluation of an electronic apex locator that uses the ratio method in vital and necrotic canals. *Journal of Endodontics* **24**, 48–50.
- Fukumoto Y (2005) Intra-canal aspiration technique for root canal irrigation: evaluation of smear layer removal. *The Journal of the Stomatological Society* **72**, 13–8.
- Fukumoto Y, Yoshioka T, Suda H (2004) Intra-canal aspiration technique for root canal irrigation. Part 1. Overflow of irrigating solution beyond the apical foramen. *The Japanese Journal of Conservative Dentistry* **47**, 37–42.
- Garberoglio R, Becce C (1994) Smear layer removal by root canal irrigants. A comparative scanning electron microscopic study. *Oral Surgery, Oral Medicine, and Oral Pathology* **78**, 359–67.
- Gernhardt CR, Eppendorf K, Kozlowski A, Brandt M (2004) Toxicity of concentrated sodium hypochlorite used as an endodontic irrigant. *International Endodontic Journal* **37**, 272–80.
- Goldberg F, Silvio ACD, Manfré S, Natri N (2002) *In vitro* measurement accuracy of an electronic apex locator in teeth with simulated apical root resorption. *Journal of Endodontics* **28**, 461–3.
- Goldman M, Kronman JH, Goldman LB, Clausen H, Grady J (1976) New method of irrigation during endodontic treatment. *Journal of Endodontics* **2**, 257–60.
- Guerisoli DMZ, Marchesan MA, Walmsley AD, LumLey PJ, Pecora JD (2002) Evaluation of smear layer removal by EDTAC and sodium hypochlorite with ultrasonic agitation. *International Endodontic Journal* **35**, 418–21.
- Hülsmann M, Hahn W (2000) Complications during root canal irrigation – literature review and case reports. *International Endodontic Journal* **33**, 186–93.
- Jenkins JA, Walker WA, Schindler WG, Flores CM (2001) An *in vitro* evaluation of the accuracy of the Root ZX in the presence of various irrigants. *Journal of Endodontics* **27**, 209–11.
- Kielbassa AM, Muller U, Munz I, Monting JS (2003) Clinical evaluation of the measuring accuracy of Root ZX in primary teeth. *Oral Surgery, Oral Medicine, and Oral Pathology* **95**, 94–100.
- Kobayashi C (1995) Electronic canal length measurement. *Oral Surgery, Oral Medicine, and Oral Pathology* **79**, 226–31.
- Kobayashi C, Suda H (1993) A basic study on the electronic root canal length measurement. Part 4. A comparison of 6 apex locators. *The Japanese Journal of Conservative Dentistry* **36**, 185–92.
- Kobayashi C, Suda H (1994) New electronic canal measuring device based on the ratio method. *Journal of Endodontics* **20**, 111–4.
- Kobayashi T, Yamada H, Inoshita M et al. (2003) Antimicrobial effects of weak acid electrolyzed water using ultra irrigating system. *The Japanese Journal of Conservative Dentistry* **46**, 439–44.
- Lussi A, Nussbächer U, Grosrey J (1993) A novel noninstrumented technique for cleansing the root canal system. *Journal of Endodontics* **19**, 549–53.
- Lussi A, Suter B, Grosrey J (1997) Obturation of root canals *in vivo* with a new vacuum technique. *Journal of Endodontics* **23**, 629–31.
- Meares WA, Steiman HR (2002) The influence of sodium hypochlorite irrigation on the accuracy of the Root ZX electronic apex locator. *Journal of Endodontics* **28**, 595–8.
- Niu W, Yoshioka T, Kobayashi C, Suda H (2002) A scanning electron microscopic study of dentinal erosion by final irrigation with EDTA and NaOCl solutions. *International Endodontic Journal* **35**, 934–9.
- O'Connell MS, Morgan LA, Beeler WJ, Baumgartner JC (2000) A comparative study of smear layer removal using different salts of EDTA. *Journal of Endodontics* **26**, 739–43.
- Ounsi HF, Naaman A (1999) *In vitro* evaluation of the reliability of the Root ZX electronic apex locator. *International Endodontic Journal* **32**, 120–3.
- Pagavino G, Pace R, Baccetti T (1998) A SEM study of *in vivo* accuracy of the Root ZX electronic apex locator. *Journal of Endodontics* **24**, 438–41.
- Richman MJ (1957) The use of ultrasonics in root canal therapy and root resection. *Journal of Dental Medicine* **12**, 12–8.
- Sedgley CM, Nagel AC, Hall D, Applegate B (2005) Influence of irrigant needle depth in removing bioluminescent bacteria inoculated into instrumented root canals using real-time imaging *in vitro*. *International Endodontic Journal* **38**, 97–104.
- Shabahang S, Goon WWY, Gluskin AH (1996) An *in vivo* evaluation of Root ZX electronic apex locator. *Journal of Endodontics* **22**, 616–8.
- Torabinejad M, Khademi AA, Babagoli J et al. (2003) A new solution for the removal of the smear layer. *Journal of Endodontics* **29**, 170–5.
- Vajrabhaya L, Tepmongkol P (1997) Accuracy of apex locator. *Endodontics & Dental Traumatology* **13**, 180–2.
- Whittaker DK, Kneale MJ (1979) The dentine–predentine interface in human teeth: a scanning electron microscope study. *British Dental Journal* **146**, 43–6.
- Yamada RS, Armas A, Goldman M, Lin PS (1983) A scanning electron microscopic comparison of a high volume final flush with several irrigating solutions: Part 3. *Journal of Endodontics* **9**, 137–42.